

RatioMatic Burners Model RM0500

DATA SHEET

Edition 05.19

Version 6

| Parameter | Specifications | | | |
|---|----------------|---|------------------------|------------------|
| | Blower Type | Chamber Pressure "w.c. (mbar) | 50 Hz | 60 Hz |
| Maximum Input, Btu/h (kW) ¹ For chamber pressures outside the given range or for varying chamber pressure conditions, contact Eclipse, Inc. | | -5.0 (-12.4) | 5,700,000 (1670) | 5,780,000 (1690) |
| | | -2.0 (-5.0) | 5,300,000 (1550) | 5,380,000 (1580) |
| | | 0.0 (0.0) | 5,010,000 (1470) | 5,100,000 (1490) |
| | | 2.0 (5.0) | 4,710,000 (1380) | 4,800,000 (1410) |
| | | 5.0 (12.4) | 4,210,000 (1230) | 4,310,000 (1260) |
| Minimum Input, Btu/h (kW) ² For lower inputs, contact Eclipse, Inc. | | 75,000 (22) | | |
| Main Gas Inlet Pressure, psig (mbar) ³ Fuel pressure at ratio regulator inlet | | Natural Gas | 1.0 to 2.0 (70 to 140) | |
| | | Propane/Butane | 1.0 to 1.5 (70 to 105) | |
| High Fire Visible Flame Length, inches (mm) Measured from the outlet end of the combustor | | Natural Gas | 56 (1430) | |
| | | Propane/Butane | 64 (1630) | |
| Maximum Chamber Temperature, °F (°C) | | Alloy Tube | 1500 (815) | |
| | | Block & Holder | 1900 (1038) | |
| Flame Detection | | Alloy Tube | Flamerod or UV Scanner | |
| | | Block & Holder | UV scanner only | |
| Fuels ⁴ For any other mixed gas, contact Eclipse, Inc. | | Natural Gas, Propane, Butane | | |
| Blower Motor Power, Hp (kW) | | | 5.4 (4) | 5.0 (3.7) |
| Weight, lbs (kg) ⁵ | | Alloy Tube | 410 (186) | |
| | | Refractory | 556 (252) | |
| Approvals | |  | | |

1 Maximum inputs for packaged blower versions are given for the standard combustion air blower without an inlet air filter.

2 Turndown input based on neutral chamber conditions. Contact Eclipse for other chamber pressures.

3 For proper performance, this pressure must be kept constant across the burner operating range.

4 See Design Guide 110 for more information about typical fuel composition and properties.

5 All weights are approximate.

• All information is based on laboratory testing. Different chamber conditions will affect the data.

• All inputs based upon gross calorific values and standard conditions; 1 atmosphere, 70°F (21°C).

• Eclipse reserves the right to change the construction and/or configuration of our products at any time without being obliged to adjust earlier supplies accordingly.

Performance Graphs

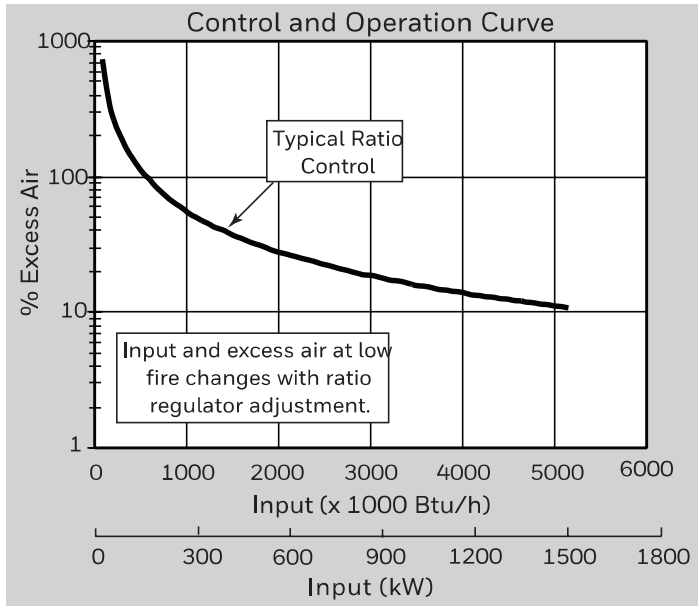

Emissions from the burner are influenced by:

- Chamber conditions
- Fuel type
- Firing rate
- Ratio regulator adjustment
- Combustion air temperature

CO emission is largely influenced by chamber conditions. Contact your local Eclipse representative for an estimate of CO emission on your application.

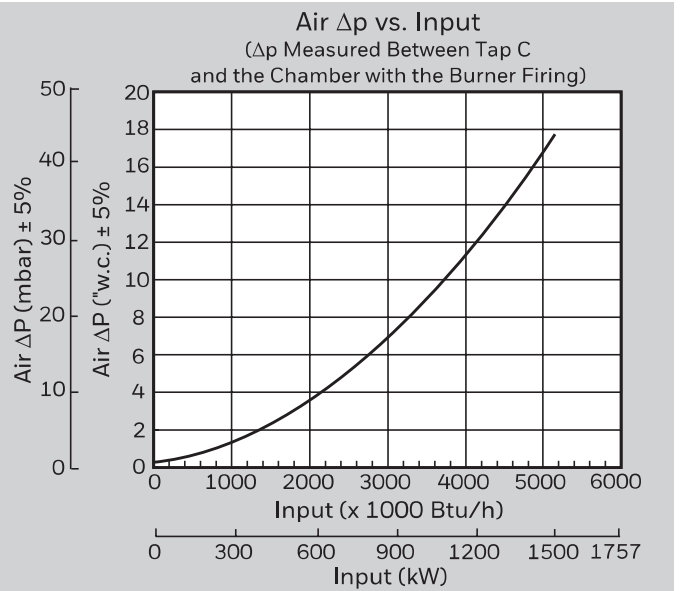
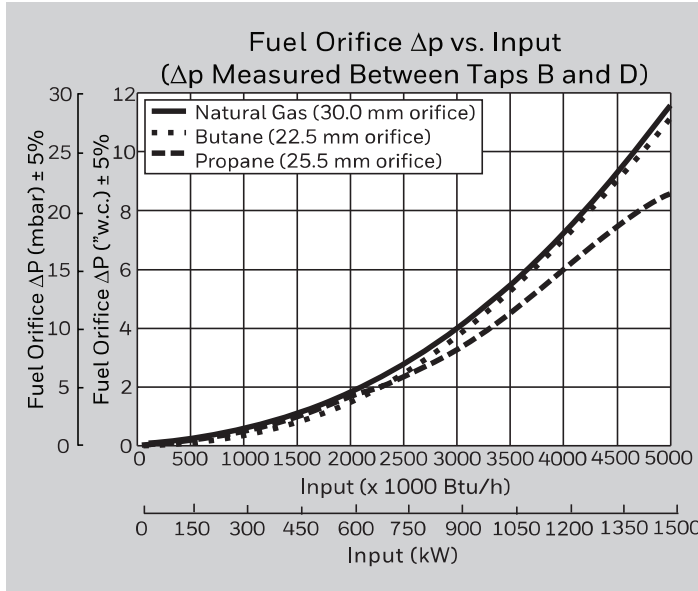

Dimensions and Specifications

Dimensions in mm (inches)

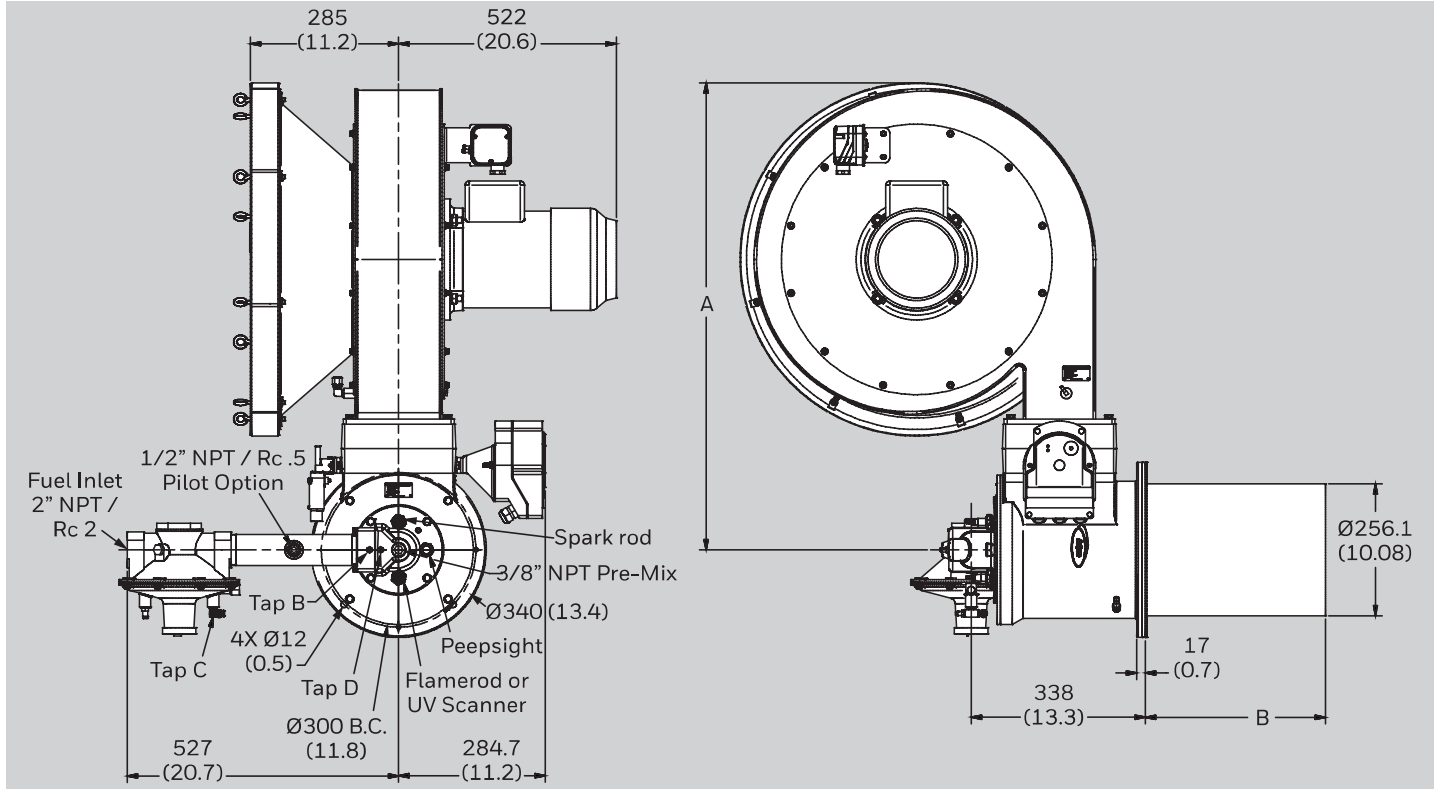

| Blower Size | A |
|-------------|------------|
| 50 Hz | 907 (35.7) |
| 60 Hz | 857 (33.7) |

| Combustor Type | B |
|-------------------------------------|--------------|
| Straight Stainless Steel Alloy Tube | 349.6 (13.8) |
| Straight Stainless Steel Alloy Tube | 425.6 (16.8) |

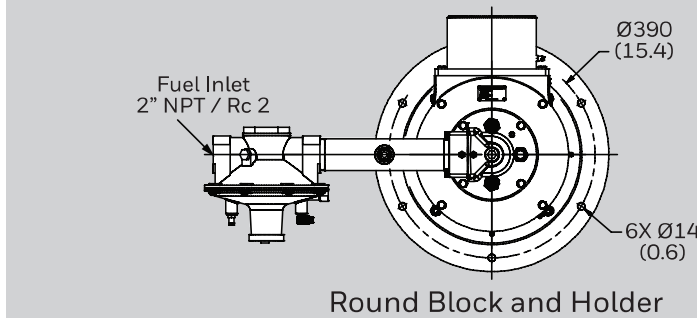
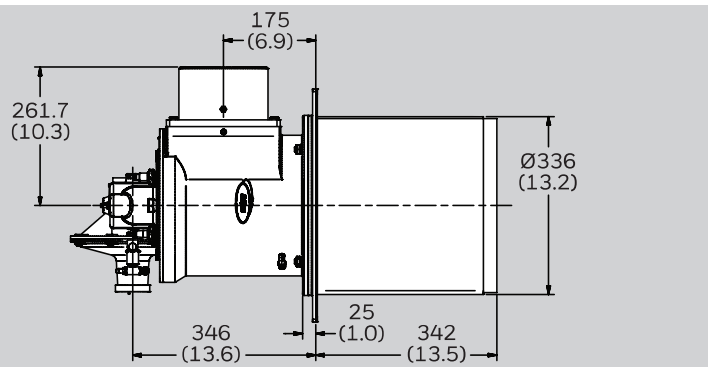
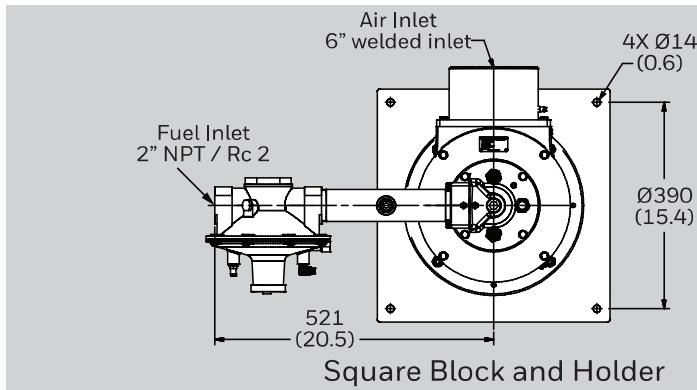

Combustor Options

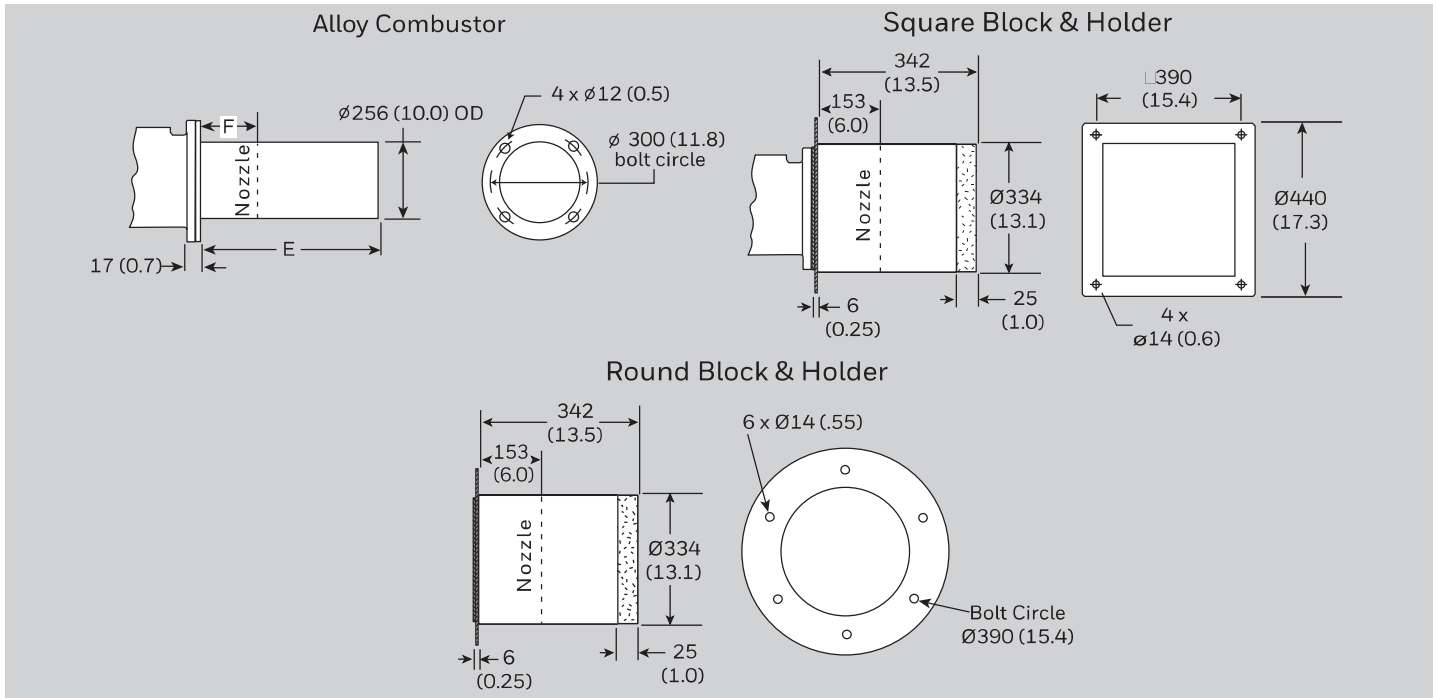

| E | F |
|------------|-----------|
| 350 (13.8) | 153 (6.0) |
| 426 (16.8) | 229 (9.0) |

Burner Configurations

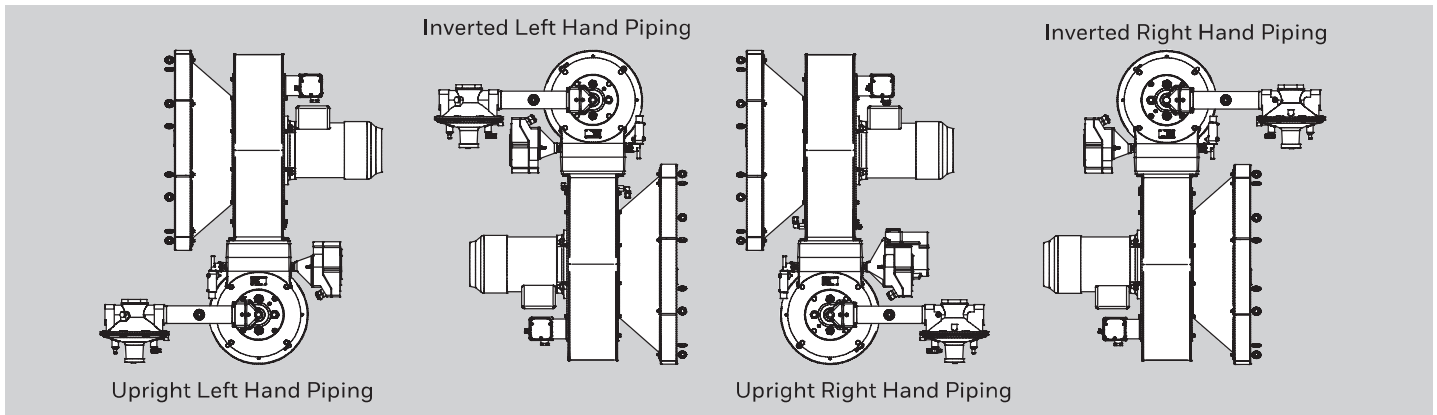

Even though the blower motor is on the “left” side of the inverted units, it is still a “right hand” motor in relationship to the blower assembly.

For More Information

The Honeywell Thermal Solutions family of products includes Honeywell Combustion Safety, Eclipse, Exothermics, Hauck, Kromschroder and Maxon. To learn more about our products, visit ThermalSolutions.honeywell.com or contact your Honeywell Sales Engineer.

Honeywell Process Solutions

Honeywell Thermal Solutions (HTS)
Eclipse Inc.
1665 Elmwood Rd.
Rockford, IL 61103
United States
T +1 815 877 3031
www.ThermalSolutions.honeywell.com

® U.S. Registered Trademark
© 2019 Honeywell International Inc.
32-00244-01 Edition 05.19
Printed in United States

Honeywell